

# ALFRED TEVES BRAKE SYSTEMS (PTY) LTD

## TECHNICAL BULLETIN

15 February 2022



(ATE and Teves are registered trademarks of Continental Teves AG & Co oHG and/or its affiliates in Frankfurt Germany and other Countries)

# ATE1276

## NEW PART NUMBER

### Drawing

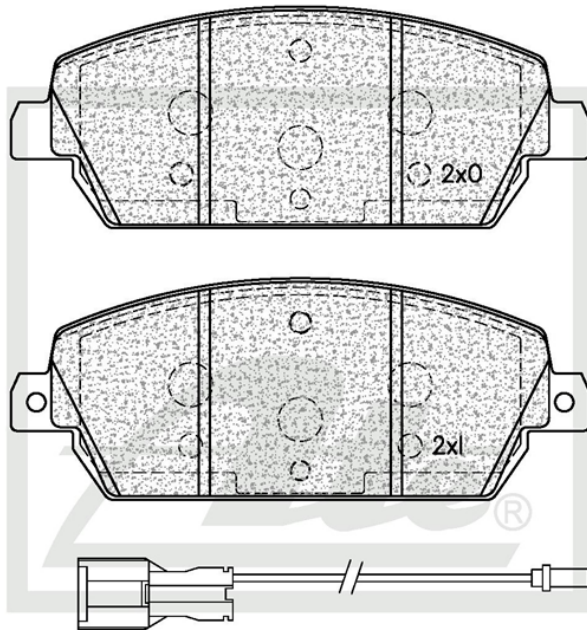

SUPPLIED WITH 2 X WEAR INDICATOR PADS PER SET  
NOTE : L + R HANDED



### Details of New Part

Brake Pad – Front

### Product Dimensions

Length – 158.1mm

Height – 60.6mm

Thickness – 18.8mm

### Package Dimensions

Weight – 2214g

L – 185.5mm

W – 100.6mm

H – 68mm

### Barcode



ATE1276

### Vehicle Applications

MAHINDRA XUV500 2.2 CRDe 2011-; MAHINDRA XUV500 2.2 CRDe AWD 2011-

Front

### Position

Rear



**CALL NOW TO ORDER YOUR STOCK!!!**

(011) 898 1800

Picture(s) of the vehicle(s) that this part is suitable for



www.ate.co.za

"Single Minded about YOUR Safety"